

Amstrad



PC7386SX

PERSONAL COLOUR COMPUTER

SERVICE MANUAL

CONTENTS

	Page
Technical Specification	2
Safety Tests	2
Main P.C.B. Top View	3
Main P.C.B. Bottom View	4
Schematic Diagrams	5 - 17
Cabinet Exploded View	18
Cabinet Parts List	19
Electrical Parts List	19

TECHNICAL SPECIFICATION

Processor	:	80386SX
Clock Speed	:	25MHz
Main on-board Memory	:	40Mb Unit
40Mb Unit	:	1Mb RAM (user expandable up to 16Mb)
80Mb Unit	:	2Mb RAM (user expandable up to 16Mb)
Memory Expansion	:	Via 4 SIMM sockets (up to 16Mb)
Hard Drive - standard	:	40Mb Fast Access (28ms) OR 80Mb Fast Access (19ms)
Floppy Disk Drive - standard	:	3.5" 1.44Mb
Disk Drive Bays	:	1 x 3.5" third height FDD bay 1 x 3.5" half height HDD bay
Expansion Slots	:	2 x 16 bit, 2/3 length ISA slots
Graphics	:	VGA (VGA, EGA, CGA, MDA and Hercules Compatible)
Video Memory	:	256Kb (expandable up to 512Kb)
Maximum resolution	:	1024 x 768 pixels
On-screen colours	:	Up to 256 (max) out of a total palette of over 250,000
External Interfaces	:	Bi-directional Parallel Port, Twin RS232C Serial Ports, PS/2 type Keyboard Socket, PS/2 type Mouse Socket, External VGA Monitor Port, External VGA Monitor Power Socket
Power Supply	:	50W 110/220-240V Auto-Switching
System Unit Dimensions	:	325mm (W) x 78mm (H) x 281mm (D)
Keyboard	:	102 key high quality PS/2 type
Mouse - standard	:	Two button PS/2 type
Supplied Software	:	MS-DOS 5.0, Amstrad Desktop (including user-friendly graphical interface and on-screen tutorial) Lotus Works 3.0 (including word processing, spreadsheet with graphics, database and communications)
Monitors	:	
VGA PC14FMD	:	14" Flat screen paper white mono
Super VGA PC14M39	:	14" Hi-Res Colour (0.39 Dot Pitch)
PC14M28	:	14" Ultra Hi-Res Colour (0.28 Dot Pitch)

Date of First Publication October 1992.
Information published latest available at time of print.
Amstrad reserves the right to supply selective components.

SAFETY TEST

All monitors are tested to the following specifications.

- Flash Test:** Test at 1.5kV RMS / 3 sec between the live and neutral poles of the mains lead and all accessible metal points on the exterior of the set.
- Insulation Resistance Test:** Test at 1.5kV RMS / 3 sec between the live and neutral poles of the mains lead and all accessible metal points on the exterior of the set to show a resistance greater than 4Mohms.
- Earth Continuity Test:** The resistance of the mains lead shall not exceed 0.5ohms.

PLEASE NOTE: When any work is completed on this unit, correct safety tests must be carried out to ensure continued electrical safety.

PLEASE NOTE: All parts shown with the part number prefix  are Safety Items and must be replaced with similar items having an identical safety specification.

All those items may be purchased direct from AMSTRAD plc.

In keeping with our policy of continually improving our service, and the technical quality of our products, we reserve the right to change component types, manufacturers, sources of supply or technical specification at any time.

AMSTRAD PLC
BRENTWOOD HOUSE, 169 KINGS ROAD, BRENTWOOD, ESSEX CM14 4EF.

SCHEMATIC DIAGRAMS SECTION

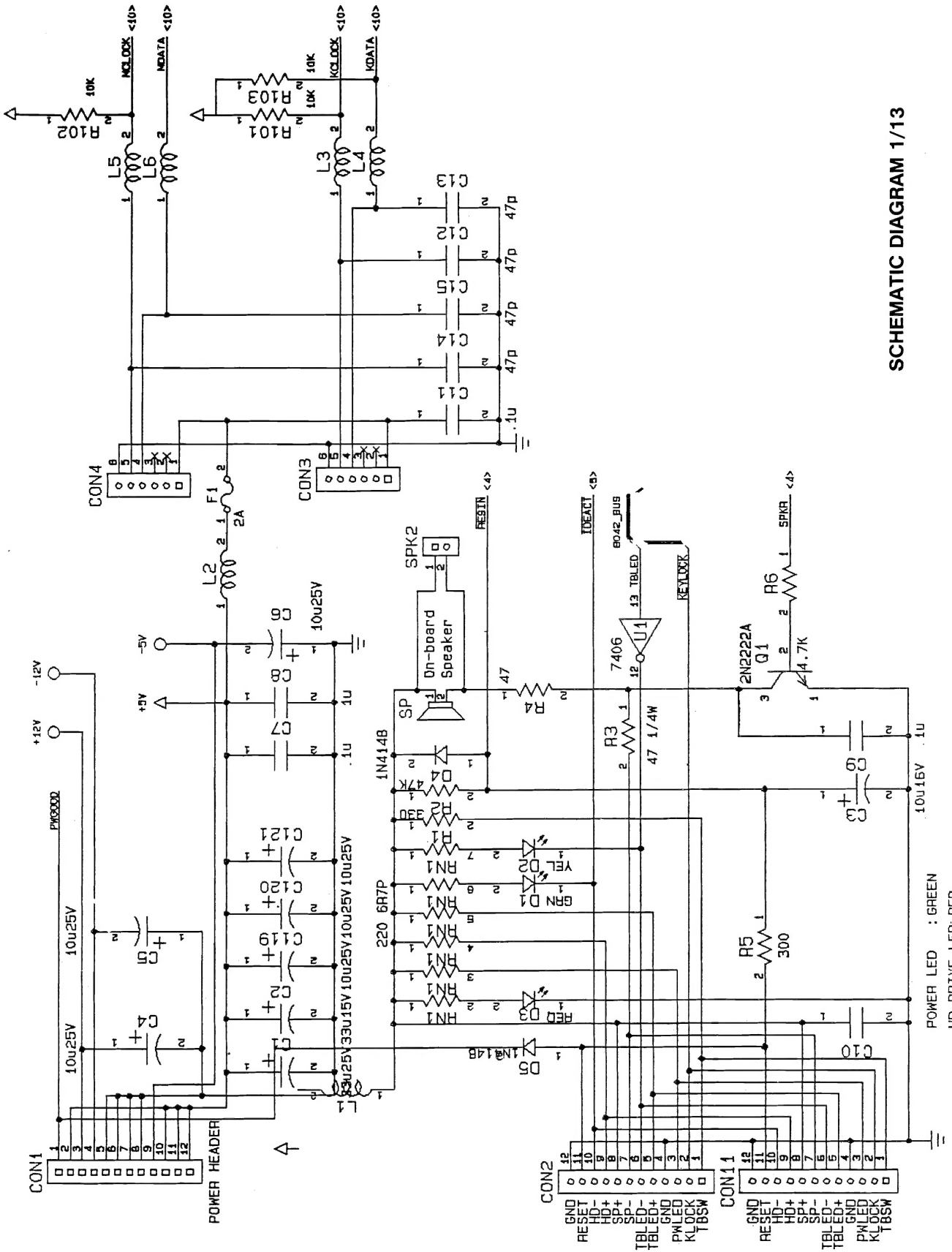

SCHEMATIC DIAGRAM 1/13

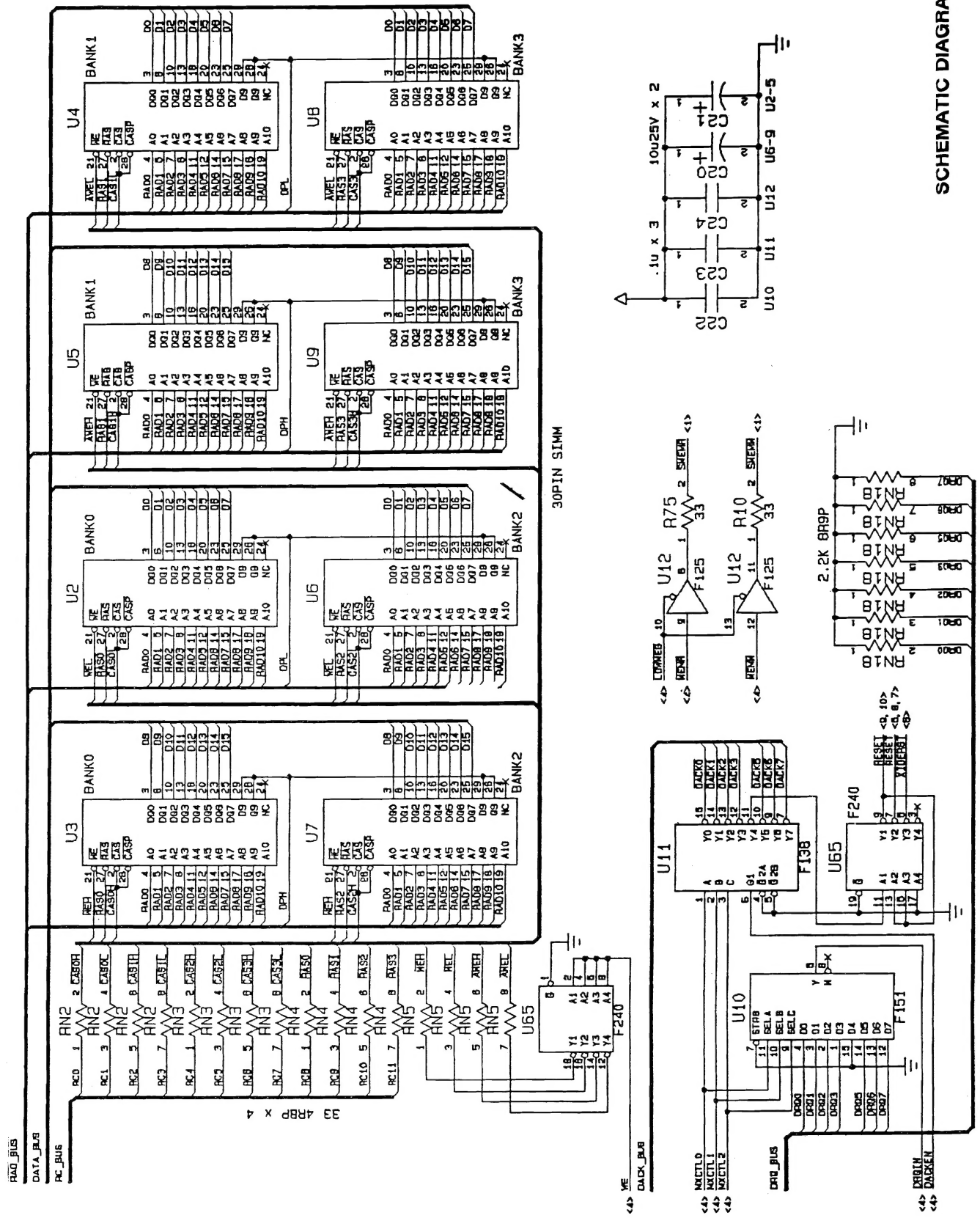

SCHEMATIC DIAGRAM 2/13

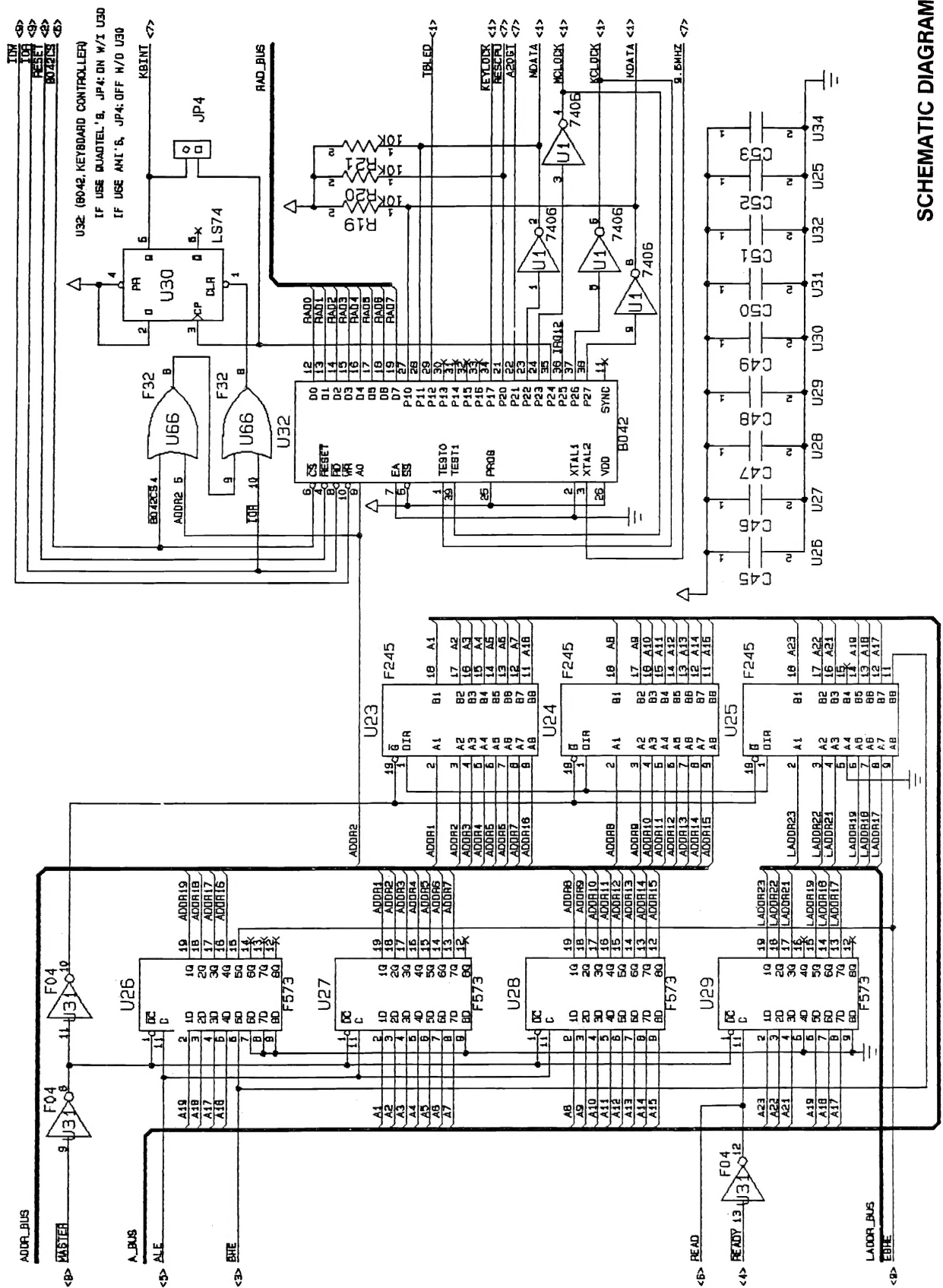

SCHEMATIC DIAGRAM 5/13

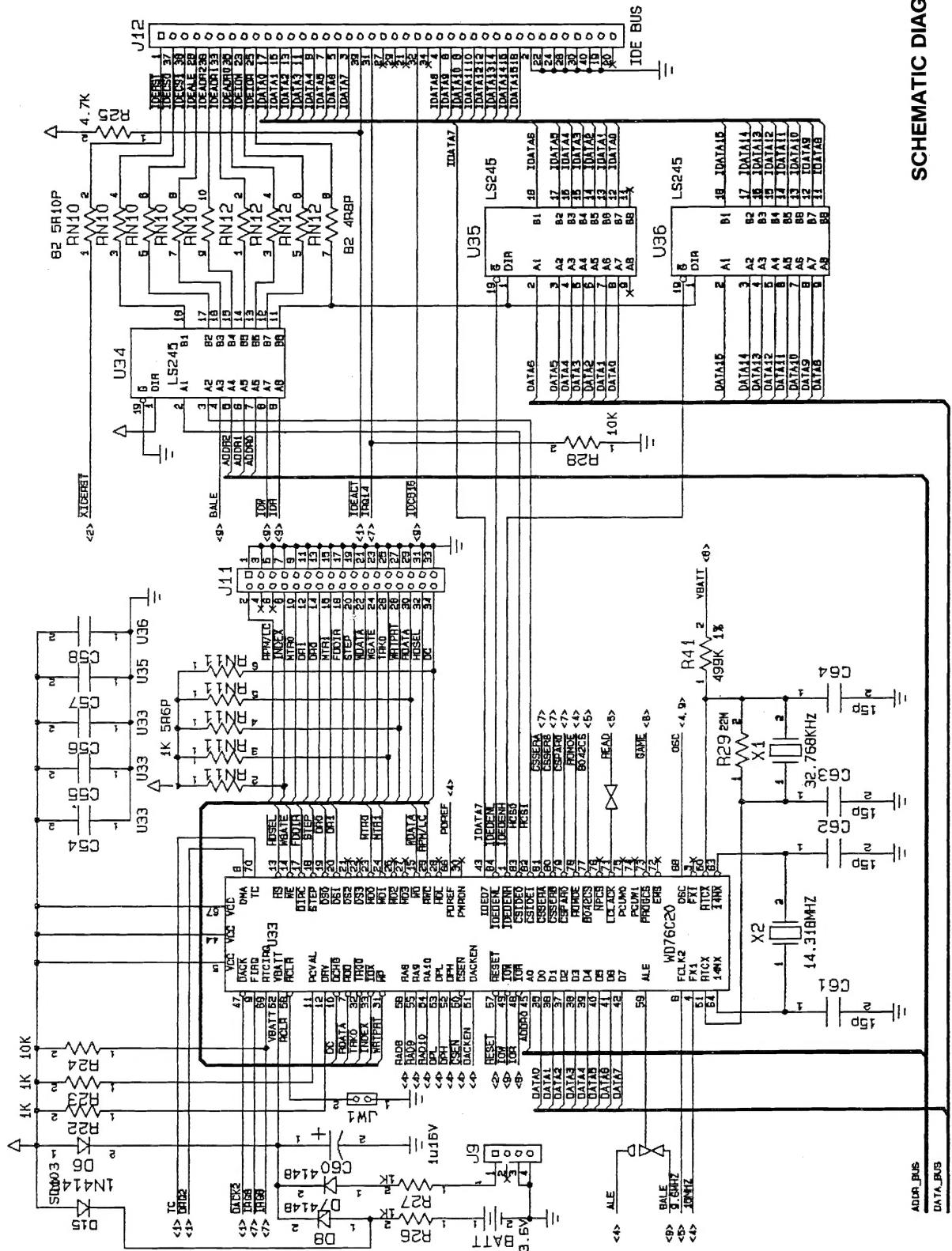

SCHEMATIC DIAGRAM 6/13

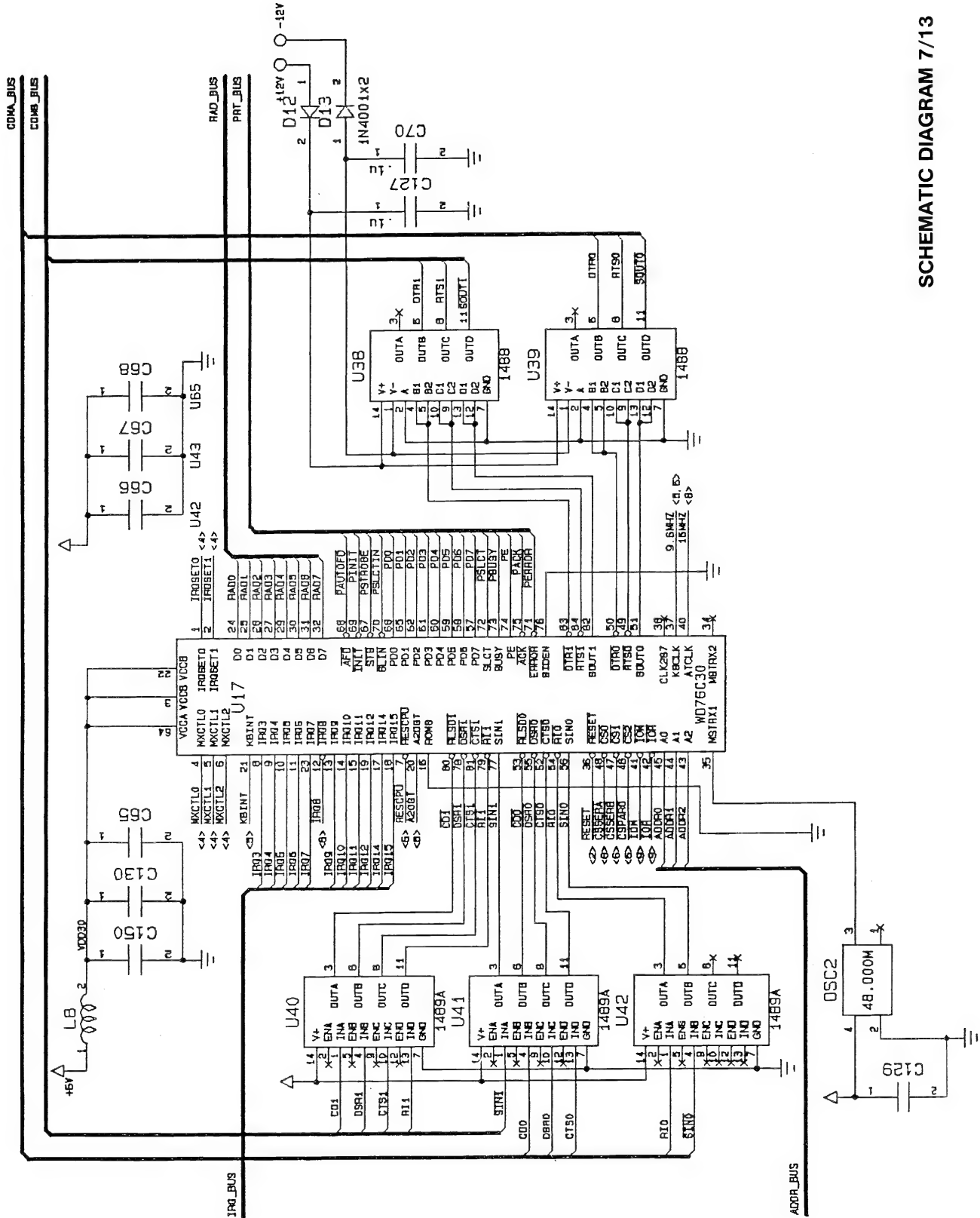

SCHEMATIC DIAGRAM 7/13

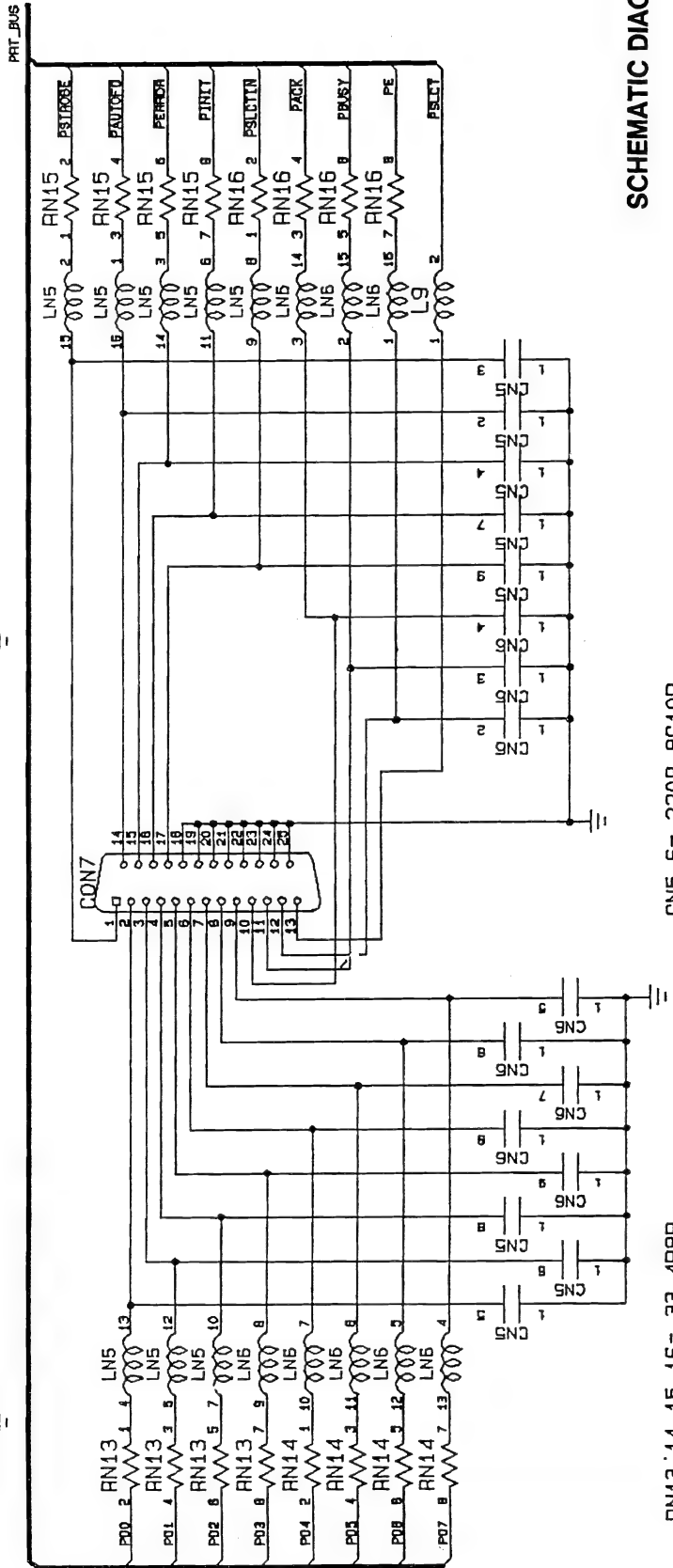
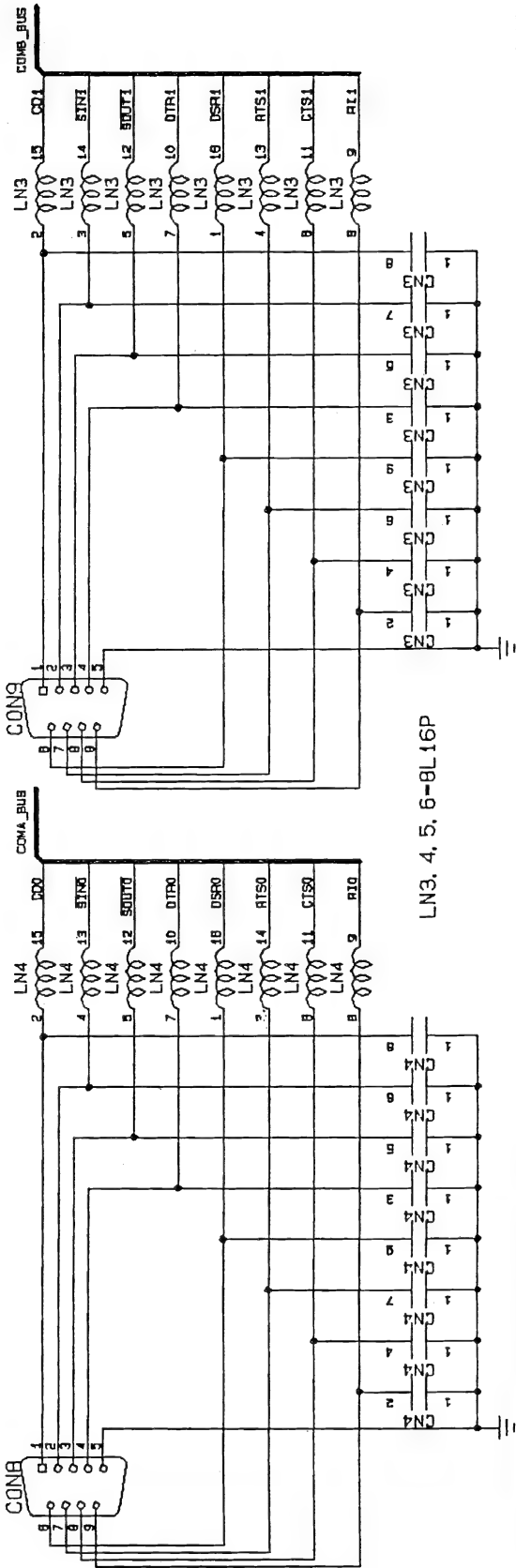

SCHEMATIC DIAGRAM 8/13

CN5, 6= 220P 8C10P

RN13, 14, 15, 16= 33 4R8P

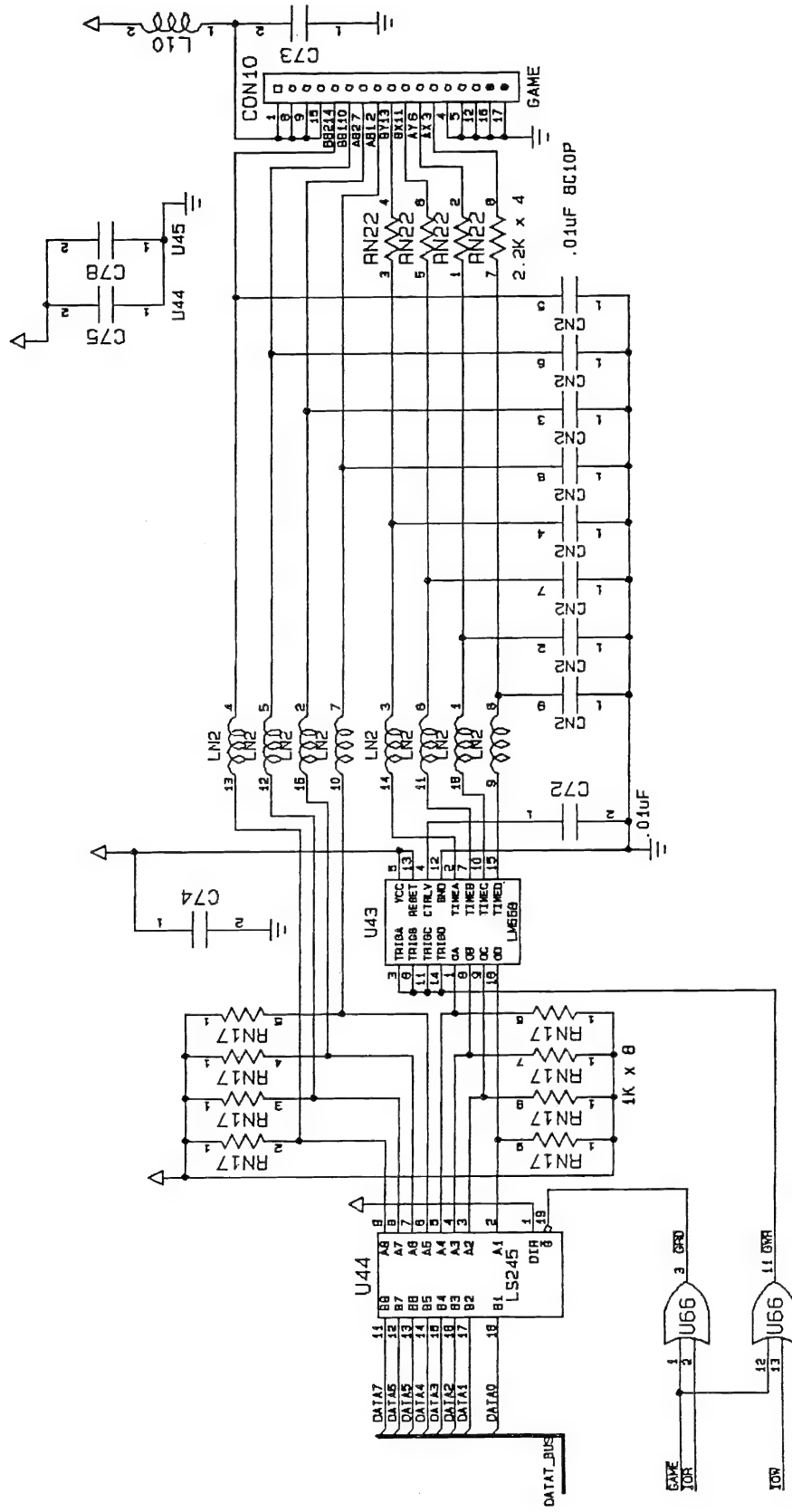

SCHEMATIC DIAGRAM 9/13

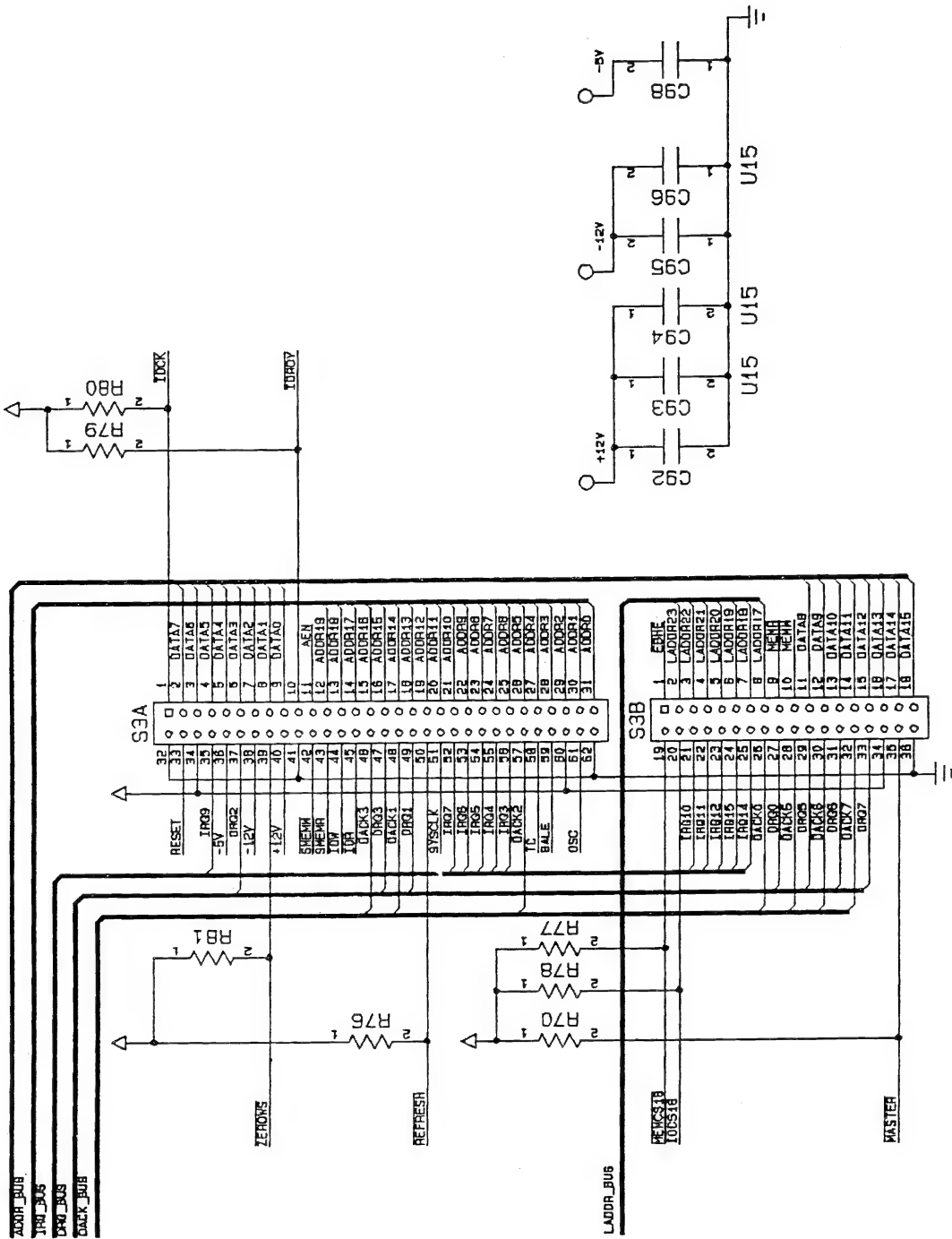

SCHEMATIC DIAGRAM 10/13

ADDR_BUS

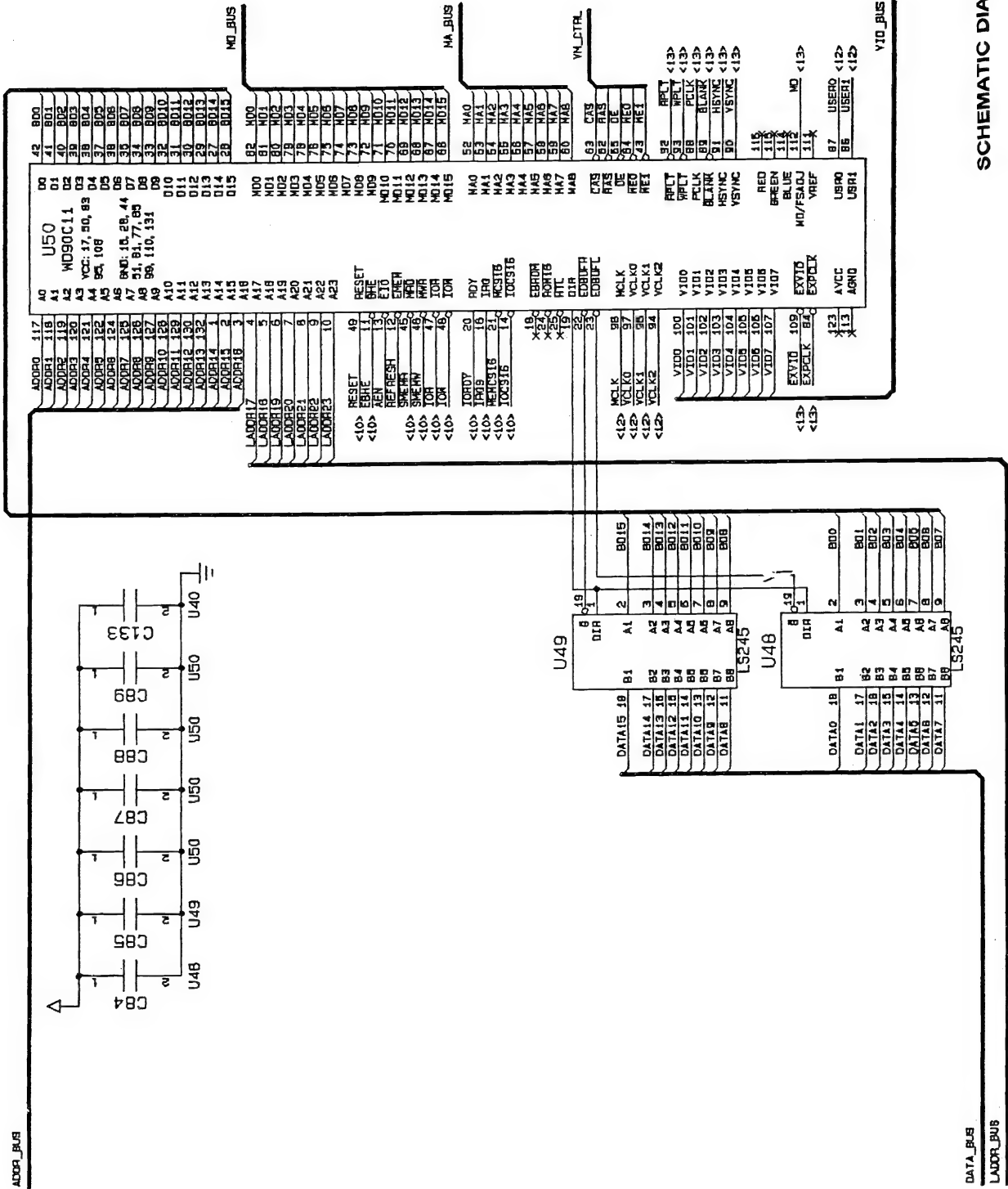
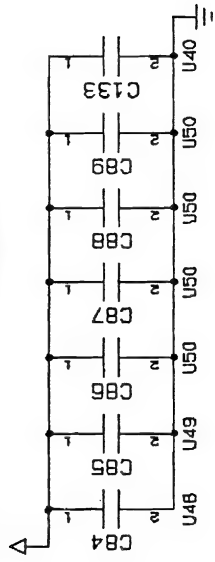

A0	U50	D0	MD0
A1	WD90C11	D1	MD1
A2	VCC: 17, 80, 83	D2	MD2
A3	82, 108	D3	MD3
A4	85, 108	D4	MD4
A5	85, 108	D5	MD5
A6	85, 108	D6	MD6
A7	85, 108	D7	MD7
A8	85, 108	D8	MD8
A9	85, 108	D9	MD9
A10	85, 108	D10	MD10
A11	85, 108	D11	MD11
A12	85, 108	D12	MD12
A13	85, 108	D13	MD13
A14	85, 108	D14	MD14
A15	85, 108	D15	MD15
A16	85, 108	D16	MD16
A17	85, 108	D17	MD17
A18	85, 108	D18	MD18
A19	85, 108	D19	MD19
A20	85, 108	D20	MD20
A21	85, 108	D21	MD21
A22	85, 108	D22	MD22
A23	85, 108	D23	MD23
A24	85, 108	D24	MD24
A25	85, 108	D25	MD25
A26	85, 108	D26	MD26
A27	85, 108	D27	MD27
A28	85, 108	D28	MD28
A29	85, 108	D29	MD29
A30	85, 108	D30	MD30
A31	85, 108	D31	MD31
A32	85, 108	D32	MD32
A33	85, 108	D33	MD33
A34	85, 108	D34	MD34
A35	85, 108	D35	MD35
A36	85, 108	D36	MD36
A37	85, 108	D37	MD37
A38	85, 108	D38	MD38
A39	85, 108	D39	MD39
A40	85, 108	D40	MD40
A41	85, 108	D41	MD41
A42	85, 108	D42	MD42
A43	85, 108	D43	MD43
A44	85, 108	D44	MD44
A45	85, 108	D45	MD45
A46	85, 108	D46	MD46
A47	85, 108	D47	MD47
A48	85, 108	D48	MD48
A49	85, 108	D49	MD49
A50	85, 108	D50	MD50
A51	85, 108	D51	MD51
A52	85, 108	D52	MD52
A53	85, 108	D53	MD53
A54	85, 108	D54	MD54
A55	85, 108	D55	MD55
A56	85, 108	D56	MD56
A57	85, 108	D57	MD57
A58	85, 108	D58	MD58
A59	85, 108	D59	MD59
A60	85, 108	D60	MD60
A61	85, 108	D61	MD61
A62	85, 108	D62	MD62
A63	85, 108	D63	MD63
A64	85, 108	D64	MD64
A65	85, 108	D65	MD65
A66	85, 108	D66	MD66
A67	85, 108	D67	MD67
A68	85, 108	D68	MD68
A69	85, 108	D69	MD69
A70	85, 108	D70	MD70
A71	85, 108	D71	MD71
A72	85, 108	D72	MD72
A73	85, 108	D73	MD73
A74	85, 108	D74	MD74
A75	85, 108	D75	MD75
A76	85, 108	D76	MD76
A77	85, 108	D77	MD77
A78	85, 108	D78	MD78
A79	85, 108	D79	MD79
A80	85, 108	D80	MD80
A81	85, 108	D81	MD81
A82	85, 108	D82	MD82
A83	85, 108	D83	MD83
A84	85, 108	D84	MD84
A85	85, 108	D85	MD85
A86	85, 108	D86	MD86
A87	85, 108	D87	MD87
A88	85, 108	D88	MD88
A89	85, 108	D89	MD89
A90	85, 108	D90	MD90
A91	85, 108	D91	MD91
A92	85, 108	D92	MD92
A93	85, 108	D93	MD93
A94	85, 108	D94	MD94
A95	85, 108	D95	MD95
A96	85, 108	D96	MD96
A97	85, 108	D97	MD97
A98	85, 108	D98	MD98
A99	85, 108	D99	MD99
A100	85, 108	D100	MD100

SCHEMATIC DIAGRAM 11/13

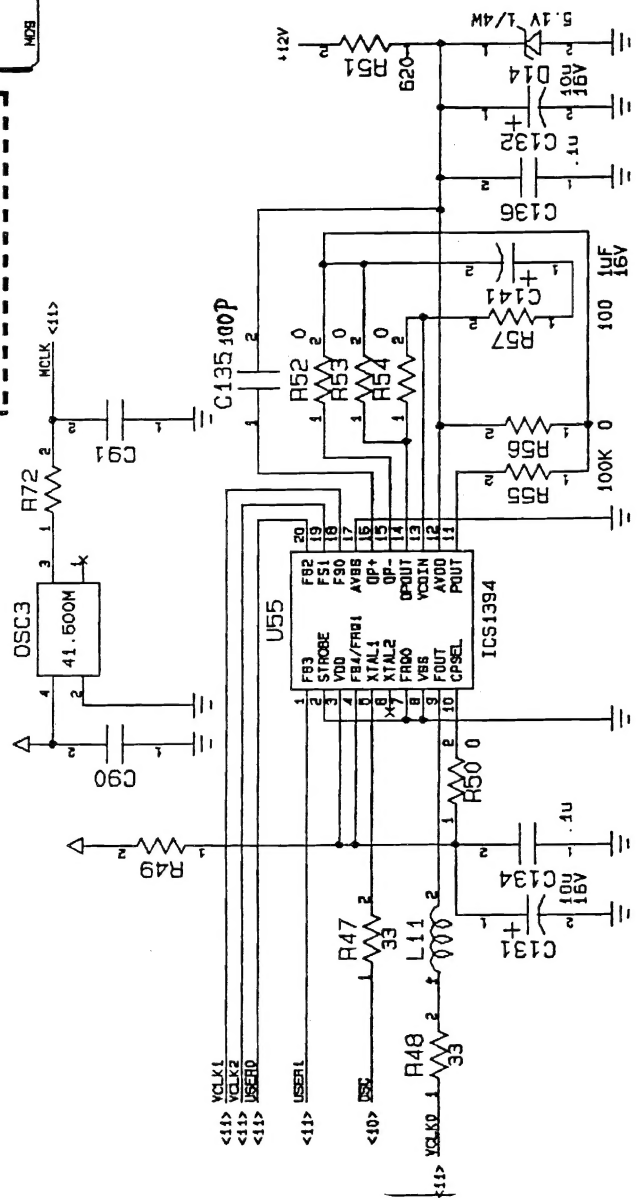
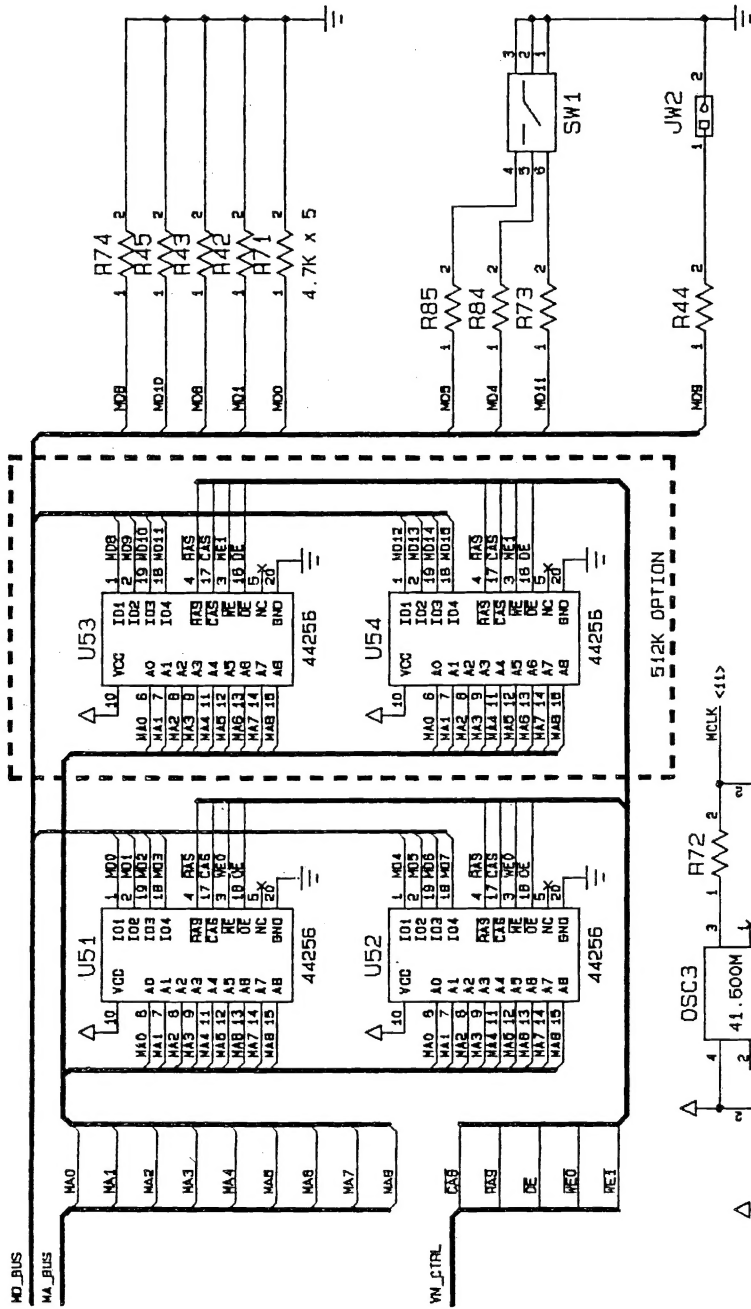

ICS1394	ICS1494	
R49	10 Ohm	FB
C136	.1uF	IN
R51, R52, R54, R55		OUT
D12, C132, C135		OUT
R53, R56		IN

SCHEMATIC DIAGRAM 12/13

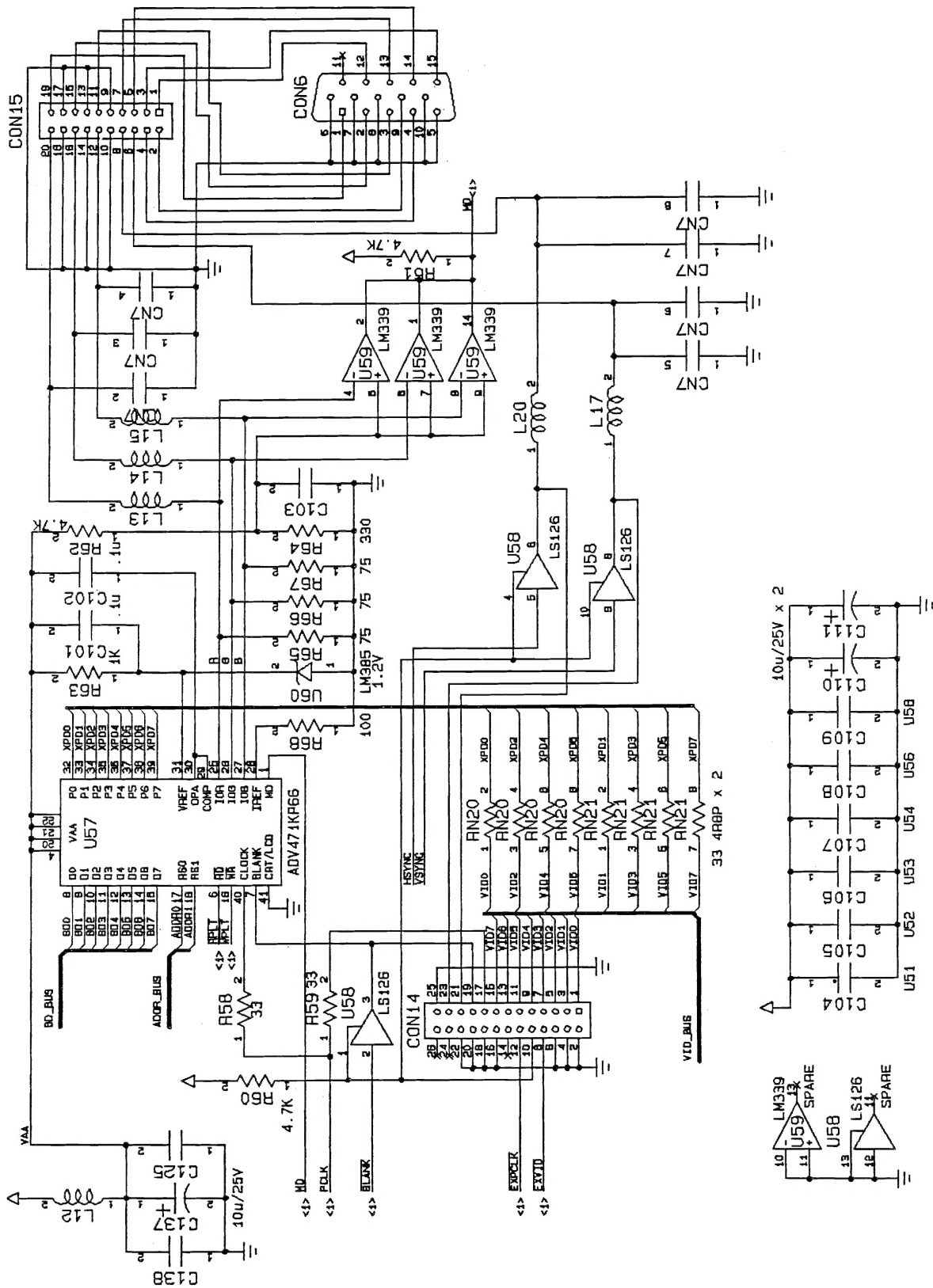

SCHEMATIC DIAGRAM 13/13

CABINET EXPLODED VIEW

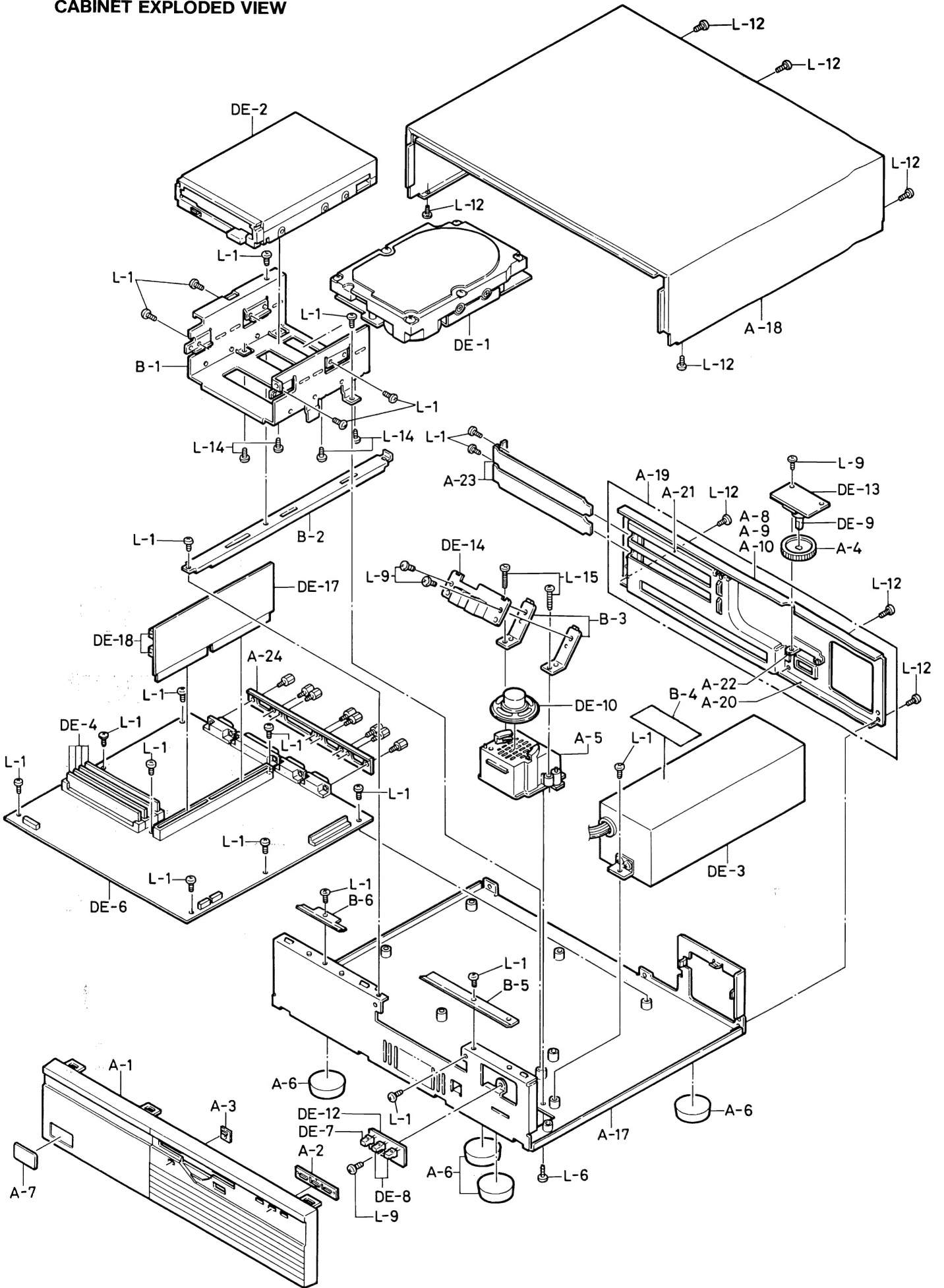

PC7386SX CABINET PARTS LIST

Ref.	Description	Part No.
A-1	Front Panel Assembly PC7386SX 40MB	273881
A-5	Front Panel Assembly PC7386SX 80MB	273887
A-4	Knob Volume Control	273892
A-5	Keyboard Mouse Cover	
A-6	Foot	
A-7	Brand Inlay	
A-8	Rating Label	
A-9	HDD Setup Label	
A-10	Serial No. Label	
A-17	Bottom	
A-18	Top Cabinet	273893
A-19	Rear Chassis Assembly	
A-23	Expansion Slot Cover	
A-24	Jack Cover	
B-1	FDD / HDD Bracket	
B-2	Bar	
DE-3	Power Supply Module	273888

PC7386SX ELECTRICAL PARTS LIST

Ref. No.	Description	Part No.
IC's		
U1	IC 7406 SFM	273930
U10	IC 74F151 SFM	273931
U11	IC 74F138 SFM	202901
U12	IC 74F125 SFM	272843
U13	IC 80386SX-25 CPU Flat Pack	273932
U15	IC WD76C10 VER:F FLat Pack	273883
U17	IC WD76C30 VER:D Flat Pack	273885
U18	IC 27C512-150 ROM Low 41651	273933
U19	IC 27C512-150 ROM High 41651	273933
U20, 22, 34-36, 48, 49, 62	IC 74LS245 SFM	272264
U23-25	IC 74F245 SFM	272245
U26-29	IC 74F573 SFM	273934
U30	IC 74F74 SFM	272242
U31	IC 74F04 SFM	272842
U32	IC 8042 Quad Op Amp	273935
U33	IC WD76C20 VER:E Flat Pack	273884
U38, 39	IC MC1488A SFM	272286
U40-42	IC MC1489A SFM	272287
U45, 66	IC 74F32 SFM	273936
U50	IC ED90C11 Flat Pack	273886
U51, 52	IC 44256-8 Dram Dip	273937
U55	IC ICS1394M-030 SFM	273938
U57	IC ADV471-66 PLCC	273939
U58	IC 74LS126 SFM	273940
U59	IC LM339 SFM	273941
U60	IC LM385Z-1.2	273942
U65	IC 74F240 SFM	273943
Transistors		
Q1	TR 2N2222A	273944
Diodes		
D3	LED Green	
D4-8, 15	D 1N4148	270754
D12, 13	D 1N4001	192506
D14	DZ 5.1V 1/4W	
Miscellaneous		
DE-2	FDD MP-F17W-10 5MM	272723
DE-1	HDD Segate ST351 (AX) UK Formated	273908
	HDD Segate ST351 (AX)	275001
	HDD Sony 80MB UK Formated	373909
	HDD Sony 80MB	41182
DE-3	Power Supply Module	273888
DE-6	Main PCB (No Simms or CPU fitted)	273894
DE-7	LED Green LN350GPH	
DE-8	LED Amber LN450YPH	
DE-9	VROT 500Ω AL001	273922
DE-10	Speaker	273923
F1△	BEL 2A MQ125V Fuse Resistor	273945
OSC1	50.00MHz Crystal	176736
OSC2	48.00MHz Crystal	272345
OSC3	42.00MHz Crystal	272343
X1	32.768KHz Crystal	176174
X2	14.318MHz Crystal	273162
	FDD Cable Assy	273925
	HDD Cable Assy	273926
	Main PCB Assy	273894
	LED PCB Assy	273891
	Expansion PCB Assy	
	Volume PCB Assy	
	Mains Lead UK	270053
	Mains Lead Euro	271067
	User Instructions 41774	273903
	MSDOS Instructions	273927
	Counter Point Instructions	273928
	Disk Set MSDOS + Counterpoint	273929
	Complete Keyboard Assy UK/HL	273895
	Complete Keyboard Assy SP	273900
	Complete Keyboard Assy AU	273901
	Complete Keyboard Assy FR	273899
	Complete Keyboard Assy IT	273898
	Complete Keyboard Assy GE	273897
	Carton PC7386SX HD40	273882
	Carton PC7386SX HD80	273889
	Set Poly Packing	273972